

LT 15

Spare parts
Ersatzteile
Pièces détachées
Reserve onderdelen
Repuestos
Reservdelar

REPAIR PARTS

TRACTOR - MODEL NO. LT15 (J8F1542F), PRODUCT NO. 954 13 00-36

ELECTRICAL

KEY NO.	PART NO.	DESCRIPTION
1	532144925	Battery 12 Volt 25 AMP
2	874760412	Bolt Hex Hd 1/4-20unc X 3/4
8	532156417	Case Battery Mech Hinge
16	532153664	Switch Interlock Push-In
20	873350400	Nut Jam Hex 1/4-20 Unc
21	532166182	Harness Asm Light W/4152j
22	532004152	Bulb Light #1156
24	532124780	Cable Battery 6 Ga 11" red
25	532146147	Cable Battery 6 Ga 44" red w/16 wire
26	532166180	Fuse 15 AMP
27	873510400	Nut Keps Hex 1/4-20 Unc
28	532124773	Cable Ground 6 Ga 12" black
29	532121305	Switch Plunger Nc Gray
30	532163968	Switch Ign 4 pos w/lights
33	532140401	Key Ign Molded Generic
40	532170217	Harness Ign.
41	871110408	Bolt Blk Fin Hex 1/4 - 20 x 1/2
42	532131563	Cover Terminal Red
43	532145673	Solenoid
48	532140844	Adapter Ammeter Rectangular
52	532141940	Protection Wire Loop

NOTE: All component dimensions given in U.S. inches.
1 inch = 25.4 mm.

REPAIR PARTS

TRACTOR - MODEL NO. LT15 (J8F1542F), PRODUCT NO. 954 13 00-36

CHASSIS AND ENCLOSURES

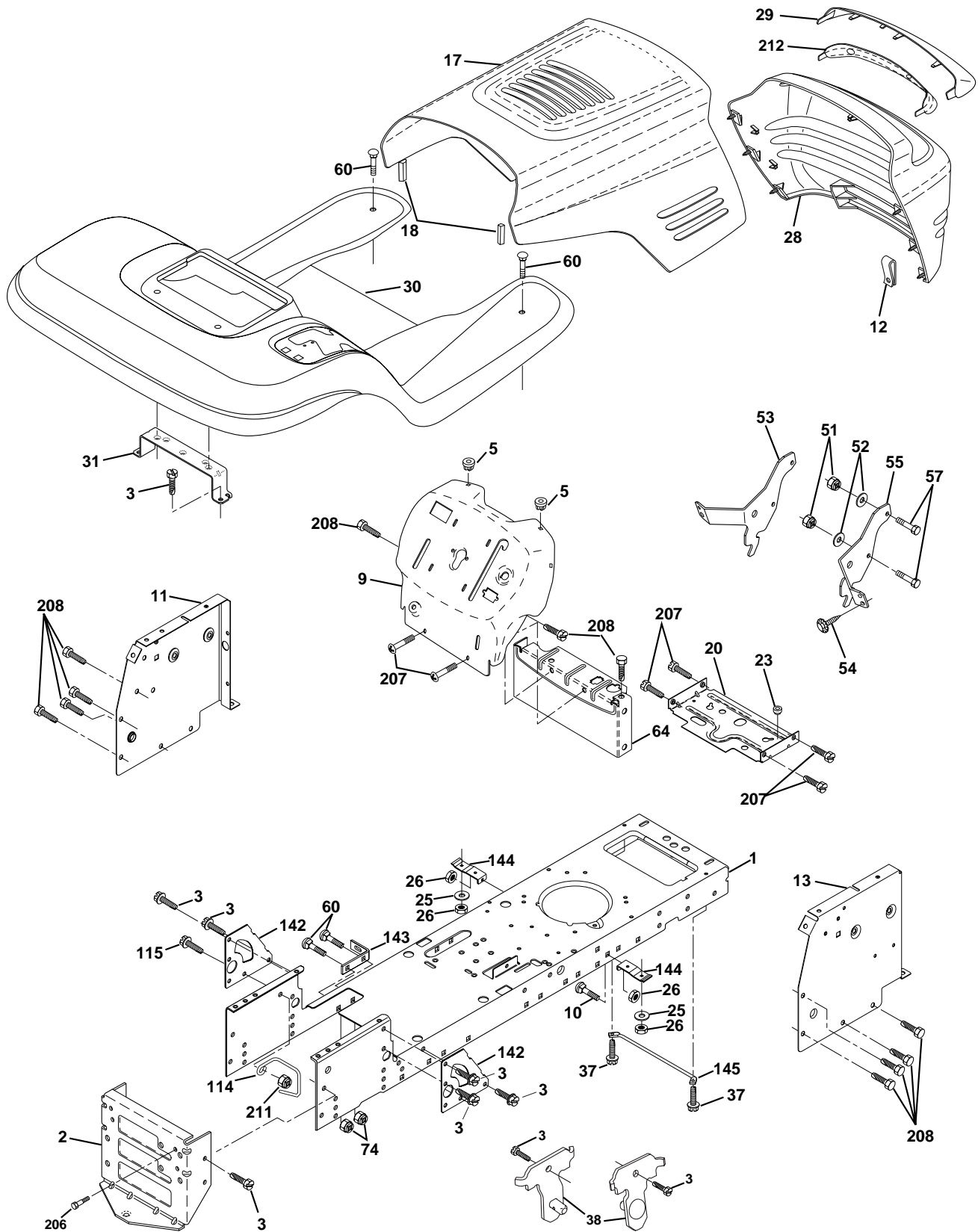

REPAIR PARTS

TRACTOR - MODEL NO. LT15 (J8F1542F), PRODUCT NO. 954 13 00-36 CHASSIS AND ENCLOSURES

KEY NO.	PART NO.	DESCRIPTION
1	532169830	Chassis Stamping
2	532169061	Drawbar
3	817060612	Screw 3/8-16x3/4
5	532155272	Bumper Hood/Dash
9	532172151	Dash P/L
10	872140608	Bolt Carriage 3/8-16 x 1
11	532155927	Panel Dash Lh
12	532145660	Clip Tinnerman Grille P/L
13	532169118	Panel Dash Rh
14	817490608	Screw Thdrol 3/8-16x1/2 Ty-tt
17	532150760	Hood LT/PL with Louvers
18	532126938	Bumper Hood
20	532156437	Plate Mtg Battery Fuel Tank Fr
23	532124028	Bushing
25	819131312	Washer 13/32 X 13/16 X 12 Ga
26	873800600	Nut Lock Hex W/Ins 3/8-16 Unc
28	532172170	Grille with Clips
29	532166603	Lens LT/PL Grille Shark Plain
30	532172157	Fender Footrest
31	532139976	Bracket Support Fender
37	817490508	Screw Thdrol 6/16-18 x 1/2 TYT
38	532169834	Bracket Asm Pivot Mower Rear
51	873800400	Nut Lock Hex W/Ins 1/4-20
52	819091416	Washer 9/32 x 7/8 x 16 Ga.
53	532145201	Bracket Pnt. Pickoff LH
54	532161464	Screw Hex Wshd 8-18 x 7/8
55	532145202	Bracket Grille Pickoff RH
57	874780412	Bolt Hex 1/4-20 x 3/4
60	872140606	Bolt Rdhd Sqnk 3/8-16unc x 3/4
64	532154798	Dash Lower STLT
74	873680600	Nut Crownlock 3/8-16 UNC
114	532158112	Keeper Belt Rear LH Stl P930
115	817060620	Screw 3/8-16 x 1-1/4
142	532165867	Plate Reinforcement STLT
143	532154966	Bracket Swaybar Chassis
144	532154207	Bracket Pnt Footrest STLT
145	532156524	Rod Pivot Chassis/Hood
206	532170165	Bolt Shoulder 5/16-18 TT
207	817670508	Screw Thdrol 5/16-18 x 1/2
208	817670608	Screw Thdrol 3/18-16 x 1/2
211	532145212	Nut Hexflange Lock
212	532165919	Insert Lens Reflective
--	532005479	Plug Button

NOTE: All component dimensions given in U.S. inches
1 inch = 25.4 mm

REPAIR PARTS

TRACTOR - MODEL NO. LT15 (J8F1542F), PRODUCT NO. 954 13 00-36

DRIVE

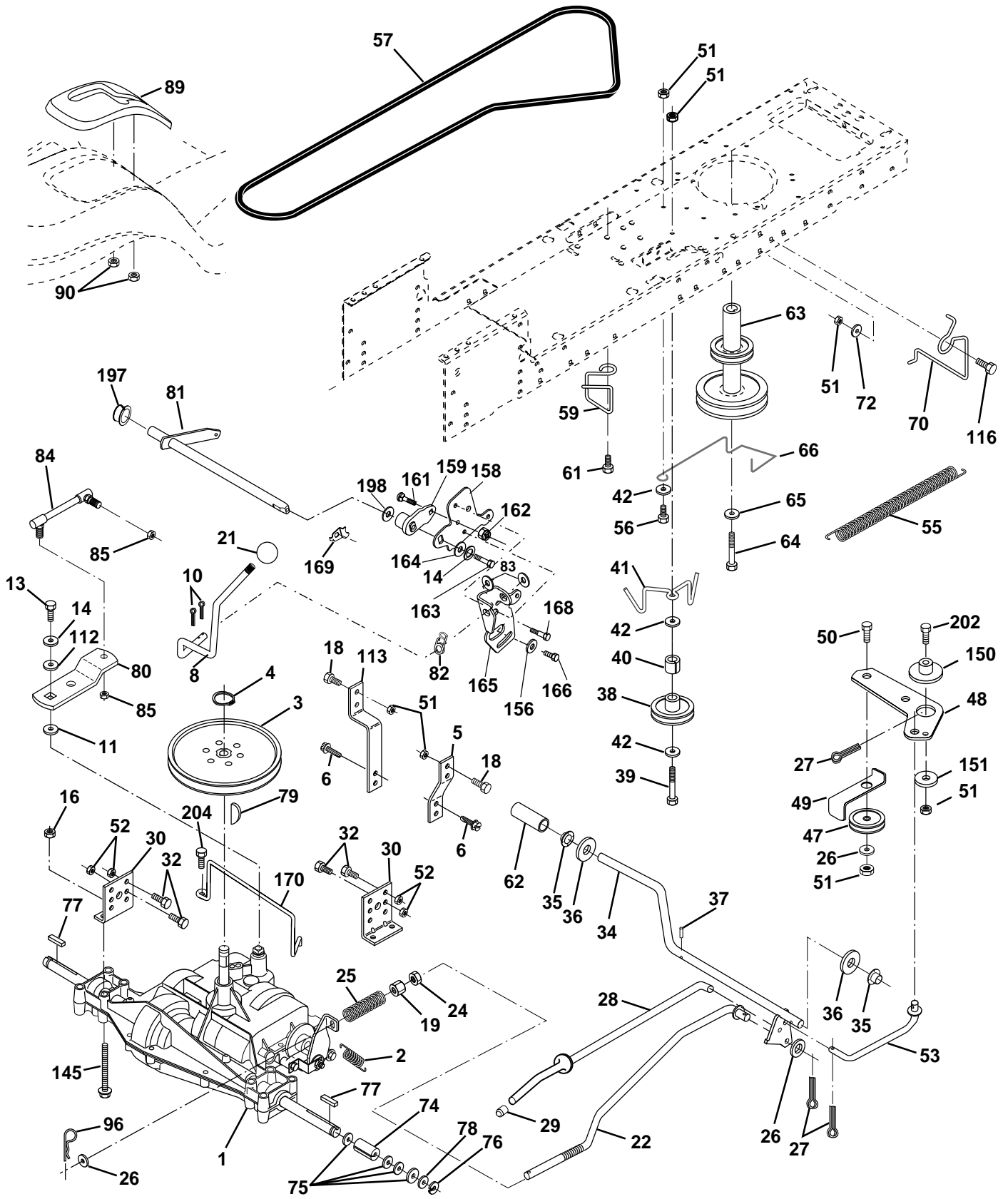

REPAIR PARTS

TRACTOR - MODEL NO. LT15 (J8F1542F), PRODUCT NO. 954 13 00-36

DRIVE

KEY NO.	PART NO.	DESCRIPTION	KEY NO.	PART NO.	DESCRIPTION
1	-----	Transaxle Peerless 206-545C (Order parts from transaxle manufacturer)	62	532124872	Cover Pedal
2	532146682	Spring Return Brake T/a Zinc	63	532140186	Engine Pulley LT/YT
3	532123666	Pulley Transaxle 18" tires	64	871170764	Bolt Hex 7/16-20 x 4
4	812000028	Ring Retainer # 5100-62	65	810040700	Washer Lock Hvy Hlcl Spr 7/16
5	532121520	Strap Torque 30 Degrees	66	532154778	Keeper Belt Engine F-Proof
6	817060512	Screw 5/16-18 X 3/4	70	532134683	Guide Belt Mower Drive RH
8	532165866	Rod Shifter	72	819132012	Washer 13/32 X 1-1/4 X 12 Ga
10	876020416	Pin Cotter 1/8 X 1 Cad	74	532137057	Spacer Axle
11	532105701	Washer Plate Shf 388 Sq Hole	75	532121749	Washer 25/32 X 1 1/4 X 16 Ga
13	874550412	Bolt 1/4-28 Unf Gr 8 W/Patch	76	812000001	E-ring #5133-75
14	810040400	Washer Lock Hvy Helical 1/4	77	532123583	Key Square 2 0 X 1845/ 1865
16	873800500	Nut Lock Hx W/Ins 5/16-18 Unc	78	532121748	Washer 25/32 X 1-5/8 X 16 Ga
18	874780616	Bolt Fin Hex 3/8-16 UNC x 1 Gr. 5	79	532125096	Key Woodruff
19	873800600	Nut Lock 3/8-16 Unc	80	532145090	Arm Shift Transaxle
21	532130564	Knob Deluxe 1/2-13 Unc Blk/Red	81	532165592	Shaft Asm Cross
22	532130804	Rod Brake Blk Zinc 26 840	82	532165711	Spring Torsion T/a
24	873350600	Nut Hex Jam 3/8-16 Unc	83	819171216	Washer 17/32 X 3/4 X 16 Ga
25	532106888	Spring Rod Brake 2 00 Zinc	84	532166231	Link Transaxle
26	819131316	Washer 13/32 X 13/16 X 16 Ga	85	532150360	Nut Nylock 1/4 - 28
27	876020412	Pin Cotter 1/8 X 3/4 Cad	89	532166556	Console Shift 6sp
28	532145204	Rod Brake Parking LT/YT	90	532124346	Nut Self-thd Wsh-hd 1/4 Zinc
29	532071673	Cap Brake Parking Black	96	532124788	Retainer Spring 1" Zinc/Cad
30	532169592	Bracket Mtg Transaxle	112	819091210	Washer 9/32 x 3/4 x 10 Ga.
32	874760512	Bolt Hex Hd 5/16-18unc X 3/4	113	532127285	Strap Torque Lt
34	532155071	Shaft Asm Pedal Foot	116	872110610	Bolt Rd Sq Neck 3/8-16 x 1-1/4
35	532120183	Bearing Nylon Blk 629 Id	145	874490540	Bolt Hex 5/16-18FLGHD
36	819211616	Washer 21/32 X 1 X 16 Ga	150	532165850	Bushing Bellcrank GRD Drive
37	532124963	Pin Roll 3/16 X 1"	151	819133210	Washer 13/32 x 2 x 10 Ga.
38	532131494	Pulley Idler Flat	156	532166002	Washer Srrted 5/16 ID x 1 .125
39	872110622	Bolt Rdhd 3/8-16 Unc x 2-3/4 Gr 5	158	532165589	Bracket Shift Mount
40	532124965	Spacer Split 395 X 59 Bzp	159	532165494	Hub Tapered Flange Shift LT
41	532165838	Keeper Belt Idler	161	872140406	Bolt Rdhd Sqnc 1/4-20 x 3/4 Gr 5
42	819131312	Washer 13/32 X 13/16 X 12 Ga	162	873680400	Nut Crownlock 1/4-20 Unc
47	532127783	Pulley Idler V Groove Plastic	163	874780416	Bolt Hex Fin 1/4-20 Unc x 1 Gr. 5
48	532154407	Bellcrank Clutch Grnd Drw STL	164	819091010	Washer 5/8 x .281 x 10 Ga.
49	532123205	Retainer Belt Style Spring	165	532165623	Bracket Pivot Lever
50	874760624	Bolt Hex Hd 3/8-16unc X 1-1/2	166	532166880	Screw 5/16-18 x 5/8
51	873680600	Nut Crownlock 3/8-16 Unc	168	532165492	Bolt Shoulder 5/16-18 x .561
52	873680500	Nut Crownlock 5/16-18 Unc	169	532165580	Plate Fastening LT
53	532105710	Link Clutch 7 66	170	532165849	Keeper Belt Transaxle Gear
55	532105709	Spring Return Clutch 6 75	197	532169613	Nyliner Snap-In 5/8" ID
56	874760620	Bolt Fin Hx 3/8-16 X 1/4	198	532169593	Washer Nyl 7/8 ID x .105"
57	531013136	V-Belt Ground Drive 95 25 42"	202	872110612	Bolt Carr Sh 3/8-16 x 1-1/2 Gr 5
59	532169691	Keeper Belt Span Ctr	204	817060516	Screw 5/16-18 x 1
61	817060612	Screw 3/8-16x3/4			

NOTE: All component dimensions given in U.S. inches
1 inch = 25.4 mm

REPAIR PARTS

TRACTOR - MODEL NO. LT15 (J8F1542F), PRODUCT NO. 954 13 00-36

STEERING ASSEMBLY

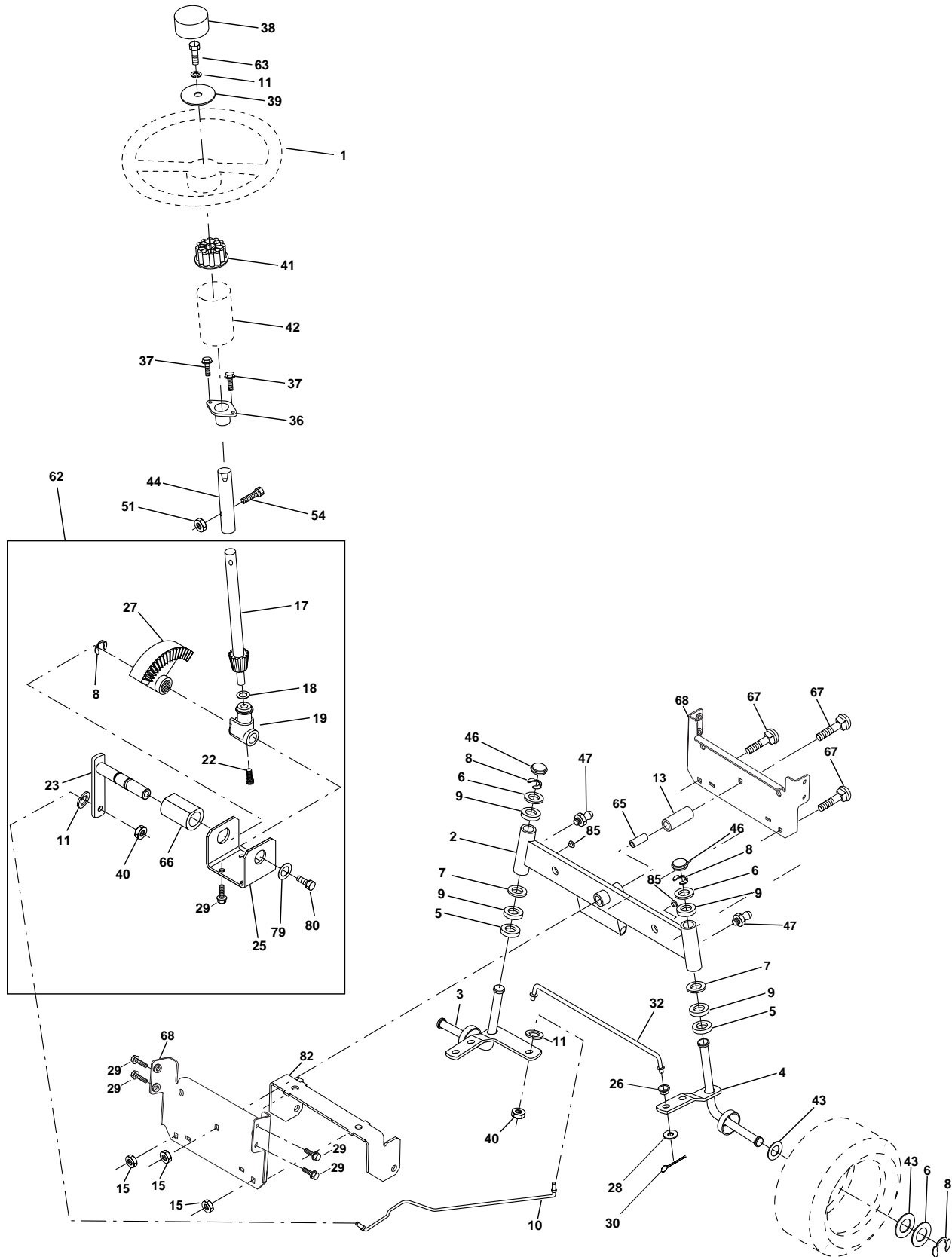

REPAIR PARTS

TRACTOR - MODEL NO. LT15 (J8F1542F), PRODUCT NO. 954 13 00-36

STEERING ASSEMBLY

KEY NO.	PART NO.	DESCRIPTION
1	532172092	Wheel Steering
2	532154427	Axle Asm STMP Dropped STL
3	532169840	Spindle Asm LH
4	532169839	Spindle Asm RH
5	532124931	Bearing Race Thrust Harden
6	532121748	Washer 25/32 X 1-5/8 X 16 Ga
7	819272016	Washer 27/32 X 1-1/4 X 16 Ga
8	812000029	Ring Klip #t5304-75
9	532124937	Bearing Col Strg Blk
10	532169832	Link Drag
11	810040600	Washer Lock Hvy Hlcl Spr 3/8
13	532136518	Spacer Brg Axle Front
15	532145212	Nut Hex Flange Lock
17	532156546	Shaft Asm Strg
18	532057079	Washer Thrust 515x 750x 033
19	532160395	Support Shaft
22	532165857	Screw Hex Wsh hd Torx
23	532165851	Shaft Asm Pittman
25	532154406	Bracket Steering
26	532126847	Bushing Link Drag
27	532136874	Gear Sector
28	819131416	Washer 13/32 X 7/8 X 16ga.
29	817060612	Screw 3/8-16x3/4
30	876020412	Pin Cotter 1/8 X 3/4 Cad.
32	532130465	Rod Tie
36	532155099	Bushing Strg
37	532152927	Screw
38	532172093	Insert Cap Strg Wh
39	819132411	Washer 13/32 X 1-1/20 x 11 Ga
40	532124701	Lock nut
41	532159945	Adaptor Wheel Strg
42	532169633	Boot Steering Shaft
43	532121749	Washer 25/32 X 1 1/4 X 16 Ga
44	532153720	Extension Steering Shaft LR/LT
46	532121232	Cap Spindle Fr Top Blk
47	532124836	Fitting Grease
51	873800500	Nut Lock Hex w/Ins 5/16-18
54	874780520	Bolt Fin Hex 5/16-18 Unc x 1-1/4
62	532167902	Kit, Steering Assembly Svc
63	874780616	Bolt Fin Hex 3/8-16unc x 1 Gr. 5
65	532160367	Spacer Brace Axle
66	532154404	Bearing Arm Pittman
67	872110618	Bolt Rdhd Sqnk 3/8-16 x 2-1/4
68	532169827	Axle, Brace
79	819132012	Washer 13/32 x 1-1/4 x 12 Ga
80	874950612	Bolt Hex Nylon 3/8-16 x 3/4
82	532169835	Bracket Susp Chassis Front
85	532133835	Fastner Christmas Tree

NOTE: All component dimensions given in U.S. inches.
1 inch = 25.4 mm.

REPAIR PARTS

TRACTOR - MODEL NO. LT15 (J8F1542F), PRODUCT NO. 954 13 00-36

ENGINE

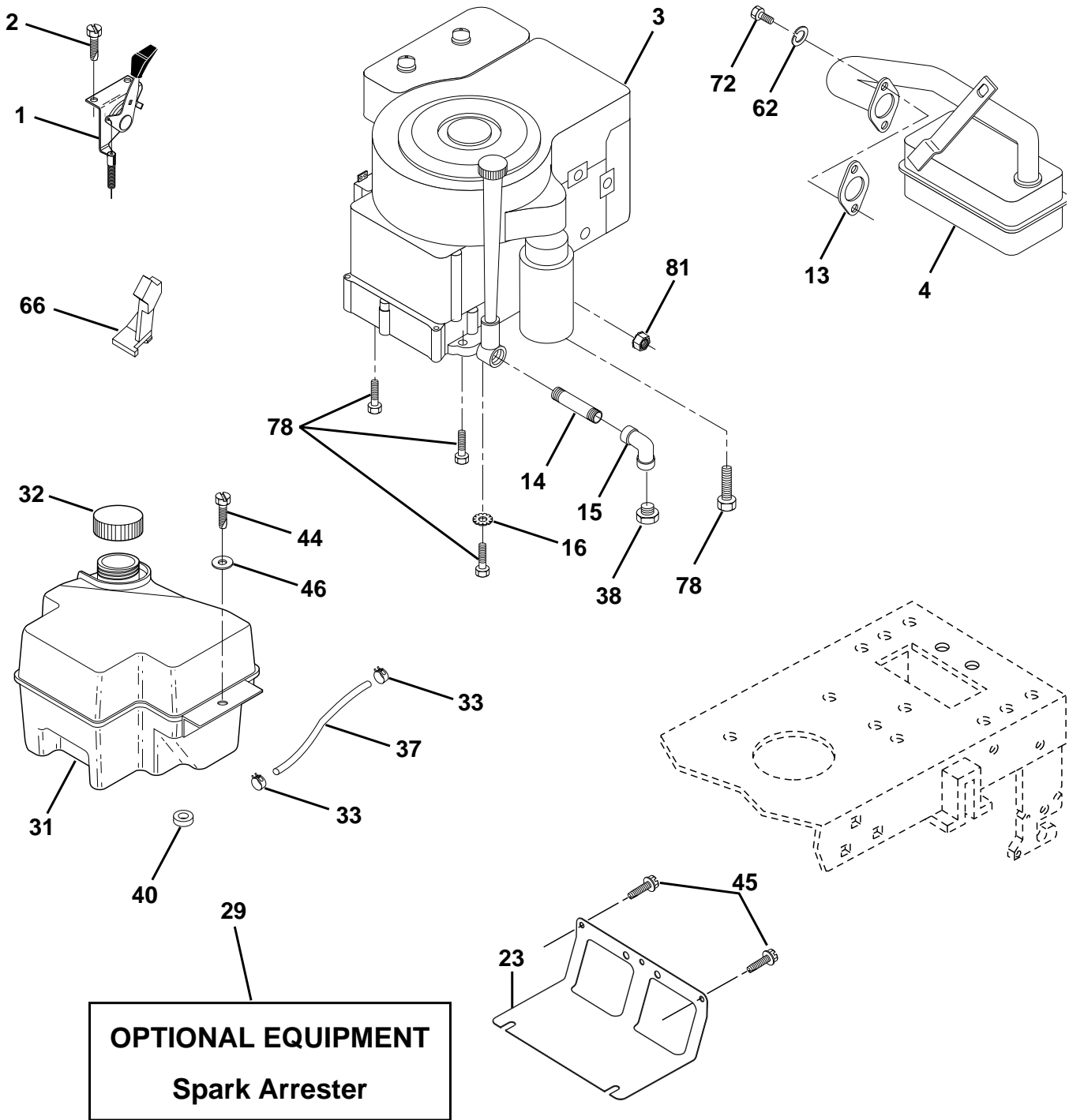

REPAIR PARTS

TRACTOR - MODEL NO. LT15 (J8F1542F), PRODUCT NO. 954 13 00-36

ENGINE

KEY NO.	PART NO.	DESCRIPTION
1	532141359	Control Th/ch 20.22 LH Flag
2	817720410	Screw Hex Thd Cut 1/4-20x5/8 T
3	-----	Engine B&S Model No. 287707 Order parts from engine manufacturer
4	532137352	Muffler LT B&S
13	532165291	Gasket
14	813280324	Nipple Pipe 3/8 Npt X 3"
15	813200300	Elbow Std 90 Degree 3/8-18 Npt
16	811050600	Washer Lock Ext Tooth 3/8
23	532169837	Shield Brn/Dbr Guard
29	532137180	Kit Spark Arrestor (Flat Scrn)
31	532161911	Tank Fuel Front 2 00
32	532140527	Cap Asm Fuel W/sym Vented
33	532123487	Clamp Hose Black
37	532137040	Line Fuel 20"
38	-----	Plug Oil Drain (Order From Engine Manufacturer)
40	532124028	Bushing Snap Nyl Blk Fuel Line
44	817490412	Screw Hexwsh Thdrol 1/4-20x3/4
45	817060612	Screw 3/8-16 x 3/4
46	819091416	Washer 9/32 X 7/8 X 16 Ga
62	810040500	Washer Lock Hvy Hlcl Spr 5/16
66	532127951	Stop Throttle 3000 RPM
72	871070512	Screw Hexhd Cap 5/16-18x 3/4
78	817060620	Screw 3/8-16x1-1/4
81	532128861	Nut Flange 1/4-20 Starter Nut

NOTE: All component dimensions given in U.S. inches
1 inch = 25.4 mm

REPAIR PARTS

TRACTOR - MODEL NO. LT15 (J8F1542F), PRODUCT NO. 954 13 00-36

SEAT ASSEMBLY

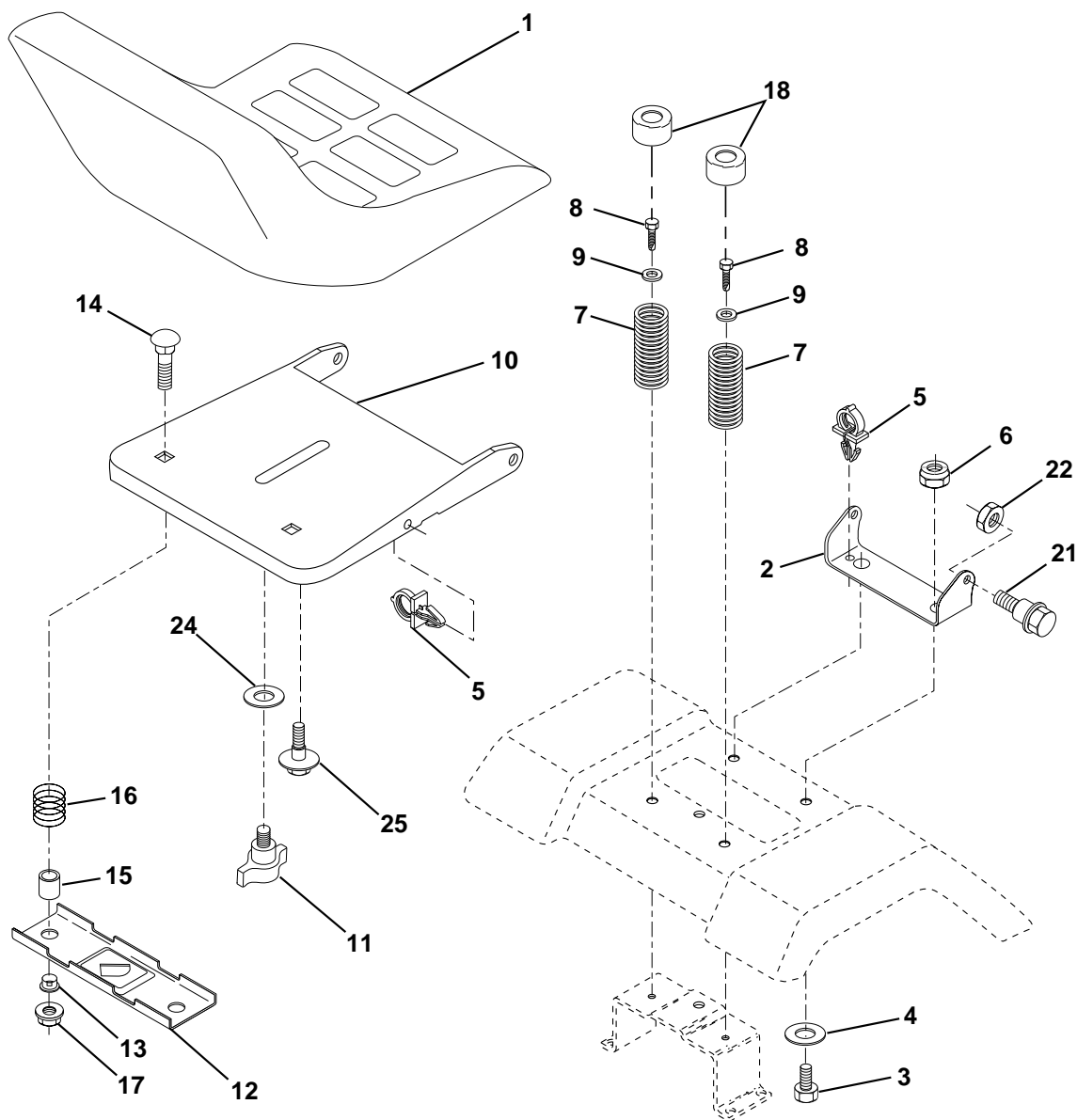

KEY NO.	PART NO.	DESCRIPTION
1	532140117	Seat
2	532140551	Bracket Pivot Seat 8 720
3	871110616	Bolt Fin Hex 3/8-16unc X 1
4	819131610	Washer 13/32 X 1 X 10 Ga
5	532145006	Clip Push-In
6	873800600	Nut Hex w/Ins. 3/8-16 Unc
7	532124181	Spring Seat Cprsn 2 250 Blk Zi
8	817000616	Screw 3/8-16 X 1-1/2
9	819131614	Washer 13/32 X 1 X 14 Ga.
10	532155925	Pan Seat
11	532166369	Knob Seat
12	532121246	Bracket Mounting Switch

KEY NO.	PART NO.	DESCRIPTION
13	532121248	Bushing Snap Blk Nyl 50 Id
14	872050412	Bolt Rdhd Sqnk 1/4-20x1-1/2
15	532134300	Spacer Split 28x96 Yel Zinc
16	532121250	Spring Cprsn 1 327 Blk Pnt
17	532123976	Nut Lock 1/4 Lge Flg Gr 5 Zinc
18	532124238	Cap Spring Seat
21	532171852	Bolt Shoulder 5/16-18 Unc
22	873800500	Nut Hex Lock W/Ins 5/16-18
24	819171912	Washer 17/32 X 1-3/16 X 12 Ga.
25	532127018	Bolt Shoulder 5/16-18 X 62

NOTE: All component dimensions given in U.S. inches.
1 inch = 25.4 mm

REPAIR PARTS

TRACTOR - MODEL NO. LT15 (J8F1542F), PRODUCT NO. 954 13 00-36

DECALS

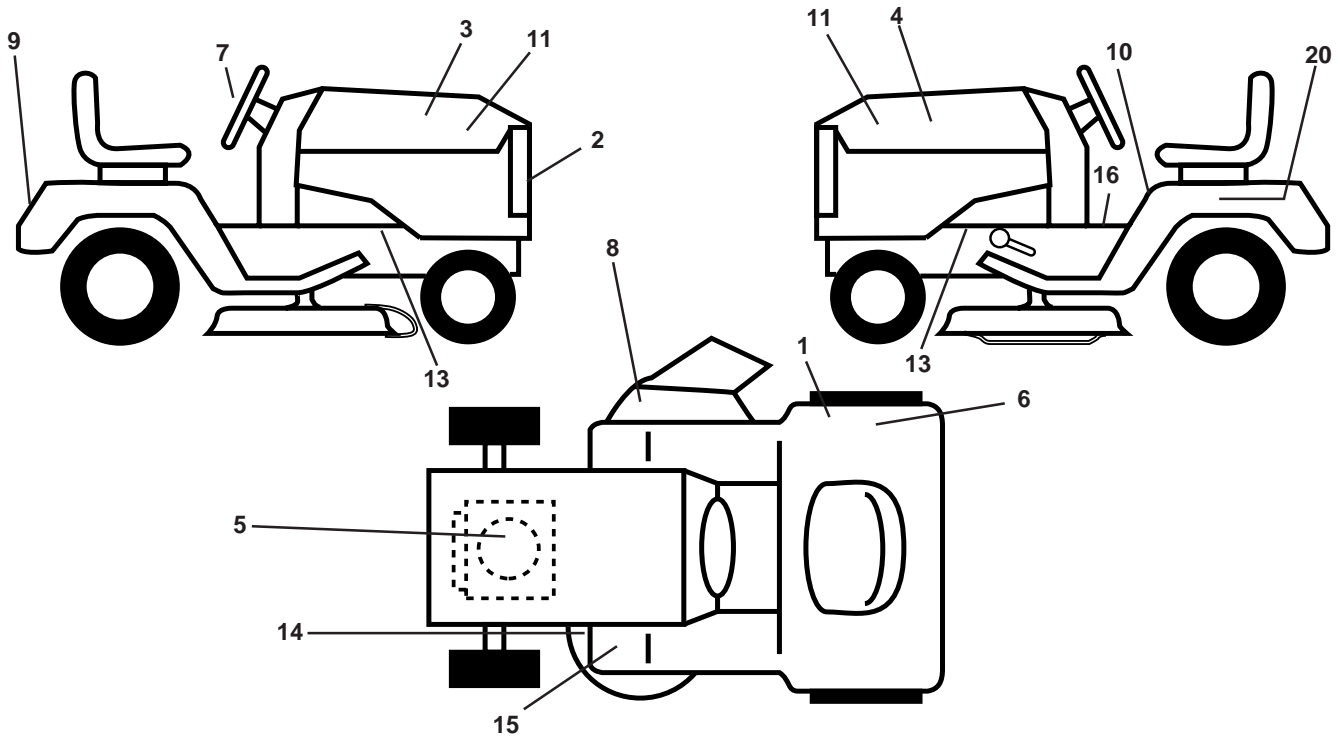

KEY NO.	PART NO.	DESCRIPTION
1	532126187	Decal 100 DBA
2	532152262	Decal Grille Jonsered Sweden
3	532170691	Decal Hood RH
4	532170692	Decal Hood LH
5	532170846	Decal HP Engine
6	532145437	Decal Europe Stand CE
7	532170565	Decal, Ins. Strg Whl. Jons.
8	532145494	Decal Mower Cutfinger
9	532141761	Decal Fender Jonsered
10	532145498	Decal Read Owner's Manual Syms.
11	532162927	Decal Hood Insert
13	532159736	Decal Chassis Hot Muffler

KEY NO.	PART NO.	DESCRIPTION
14	532160396	Decal V-Belt Schematic
15	532159737	Decal Brake/Clutch Symbol Lt
16	532140837	Decal Saddle Brake Parking
20	532145005	Decal Bat Dan/Psn
--	165800X428	Pad Footrest LH STLT
--	165799X428	Pad Footrest RH STLT
--	532138311	Decal Handle Lift Height Adjust
--	532142341	Decal Drawbar Cntrl Mvt Hyd Lt
--	532162598	Decal Drawbar Load Limit
--	532172021	Manual Operator's (Euro.)
--	532172022	Manual Operator's (Scan.)

WHEELS & TIRES

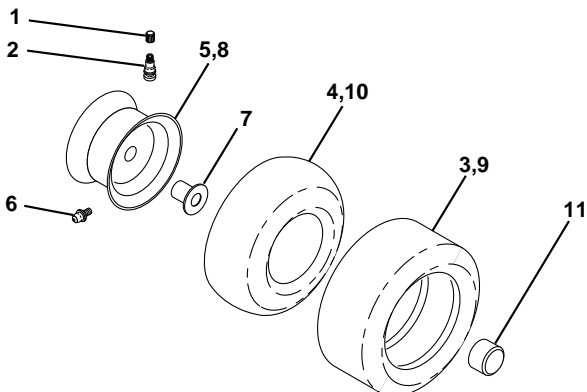

KEY NO.	PART NO.	DESCRIPTION
1	532059192	Cap Valve Tire
2	532065139	Stem Valve
3	532106222	Tire F Ts 15 X 6 0 - 6 Service
4	532059904	Tube Front (Service Item Only)
5	532138336	Rim Asm 6"front Silver Service
6	532124957	Fitting Grease (Front Wheel Only)
7	532124959	Bearing Flange (Front Wheel Only)
8	532138337	Rim Asm 8"rear Silver Service
9	532122082	Tire R Ts 20x10-8 C Service
10	532124926	Tube Rear (Service Item Only)
11	532104757	Cap Axle Blk 1 50 X 1 00
--	532144334	Sealant, Tire (10 oz. Tube)

NOTE: All component dimensions given in U.S. inches
1 inch = 25.4 mm

REPAIR PARTS

TRACTOR - MODEL NO. LT15 (J8F1542F), PRODUCT NO. 954 13 00-36

MOWER DECK

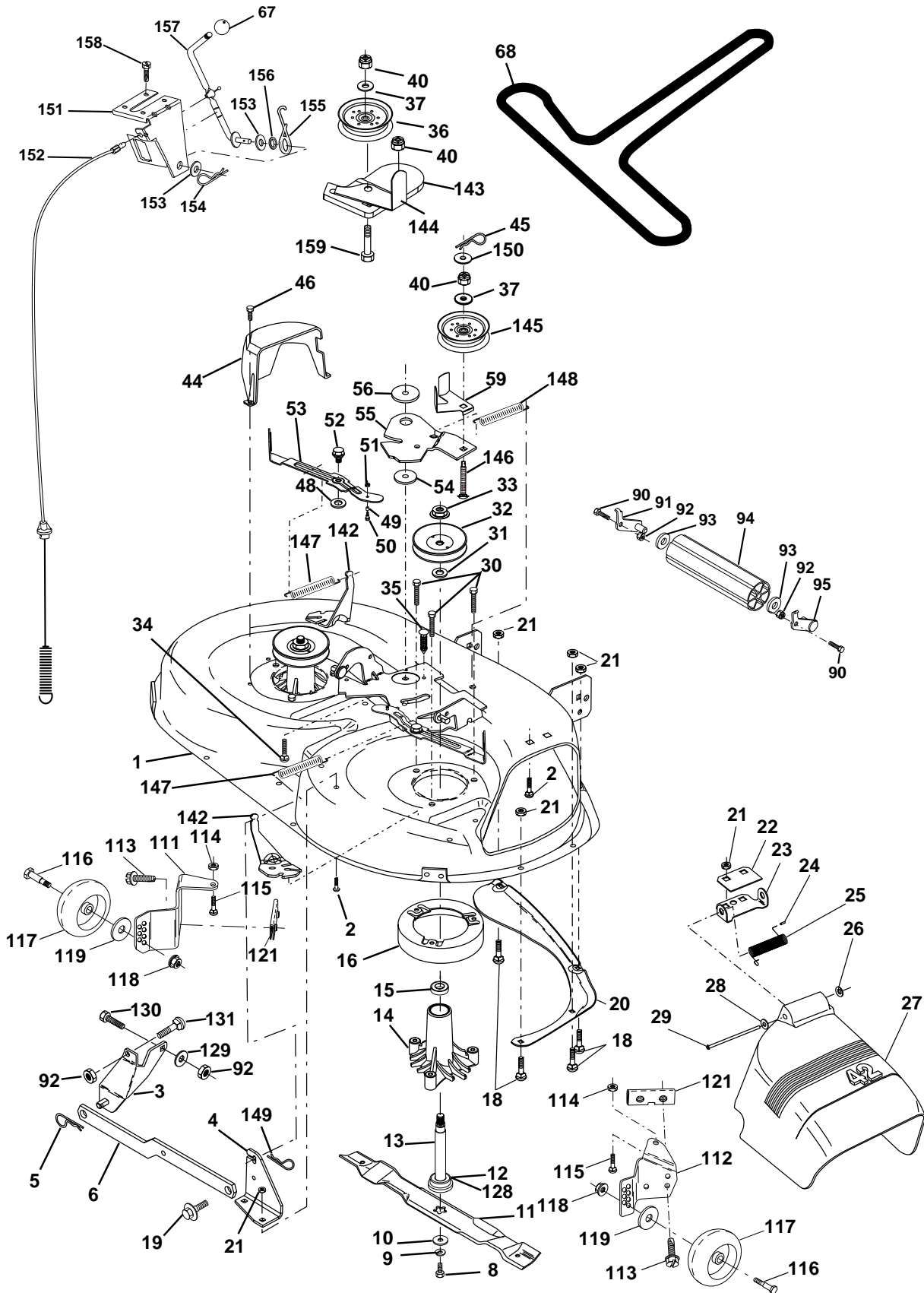

REPAIR PARTS

TRACTOR - MODEL NO. LT15 (J8F1542F), PRODUCT NO. 954 13 00-36

MOWER DECK

KEY NO.	PART NO.	DESCRIPTION	KEY NO.	PART NO.	DESCRIPTION
1	532165892	Housing Asm Mower	59	532141043	Guard, Bel
2	872140506	Bolt Rdhd Sqnk 5/16-18unc X3/4	67	532106932	Knob Rd 3/8-16 Plstc Thds Blk
3	532138017	Bracket Asm Fr Sway Bar 38/42	68	531008027	V-Belt Mower
4	532165460	Bracket Asm Deck 42"sway Bar	90	874760616	Bolt Fin Hex 3/8-16unc X 1
5	532124670	Retainer Spring	91	532132274	Bracket Asm Noseroller LH
6	532130832	Arm Suspension Rear	92	873800600	Nut Lock Hex w/ins. 3/8-16 UNC
8	532850857	Bolt 3/8-24x1 25 Gr8 Patched	93	819171416	Washer 17/32 X 7/8 X 16 Ga
9	810030600	Washer Lock Hvy 3/8 Unplated	94	532132264	Roller Nose 38 & 42
10	532140296	Washer Hard Blade Mower Vented	95	532132273	Bracket Asm Noseroller RH
11	531013134	Blade Mower High Lift"	111	532155197	Bracket Gauge Wheel Lh
12	532129895	Bearing Ball #6204 (Mandrel)	112	532155198	Bracket Gauge Wheel Rh
13	532137645	Shaft Asm W/lower Bearing	113	817060512	Screw 5/16-18 x 3/4
14	532128774	Housing Mandrel Vented(machd)	114	873510500	Nut Keps 5/16-18 UNC
15	532110485	Bearing Ball Mandrel	115	872110504	Bolt Carriage 5/16-18unc x 1/2
16	532140329	Stripper Round Mower	116	532124842	Bolt Shoulder
18	872140505	Bolt Carr 5/16-18 X 5/8	117	532165746	Wheel Gauge
19	532132827	Bolt Shoulder	118	873930600	Nut Centerlock 3/8-16 UNC
20	532159770	Baffle Vortex	119	819121414	Washer 3/8 x 7/8 x 14 Ga.
21	873680500	Nut Crown Lock 5/16-18	121	532143723	Bracket Extruded Gauge Wheel
22	532134753	Stiffener Bracket 42"deck	128	532153390	Washer Felt
23	532131267	Bracket Deflector Mower 42"	129	819131312	Washer 13/32 x 13/16 x 12 Ga.
24	532105304	Cap Sleeve 80x 112 Blk Mower	130	874780616	Bolt Fin Hex 3/8-16 UNC x 1 Gr. 5
25	532123713	Spring Torsion Deflector 2 52	131	872140608	Bolt Rdhd Sqnk 3/8-16 x 1
26	532110452	Nut Push Phos & Oil	142	532165890	Arm Spring Brake Mower
27	532171859	Shield Deflector	143	532157109	Bracket Arm Idler 42"
28	819111016	Washer 11/32 X 5/8 X 16 Ga	144	532158634	Keeper Belt 42" Clutch Cable
29	532131491	Rod Hinge 42"6 75 Wlg	145	532165888	Pulley Idler Flat
30	532157722	Screw Thdrol Washer Head	146	532165891	Bolt Carriage Idler
31	532129963	Washer Spacer Mower Vented	147	532131335	Spring Extension
32	532153535	Pulley Mandrel	148	532169022	Spring Return Idler
33	532137266	Nut 9/16top Lock Flng Cntr	149	532169898	Retainer Spring Yellow
34	872110614	Bolt RDHD 3/8-16 UNC x 2-3/4 Gr.5	150	819091216	Washer 9/32 x 3/4 x 16 Ga.
35	532133835	Fastner Christmas Tree	151	532169670	Bracket Clutch Cable
36	532131494	Pulley Idler Flat 3 060	152	532169676	Clutch Cable 42"
37	819131316	Washer 13/32 X 13/16 X 16 Ga	153	532169674	Washer Flat 3/8" Type B
40	873680600	Nut Lock 3/8-16 Unc	154	532169675	Spring Retainer
44	532140088	Guard Mandrel LH Black	155	532169671	Spring Retention Lvr Cltch Cab
45	532124788	Spring Retainer 1" Zinc/cad	156	532169672	Spacer Clutch Cable
46	532137729	Screw Thdrol 1/4-20x5/8	157	532169669	Rod Clutch Cable 3/8"
48	532133944	Washer Hardened Samllr	158	817720410	Screw Hex Thd Cut 1/4-20 x 5/8
49	532155066	Roller Asm Cam Follower 42" dec	159	872140614	Bolt Rdhd Sqn 3/8-16 Unc x 1-3/4
50	532131340	Bolt Shldr 10-24 Zinc Gr 5 42"	--	532171491	Deck Serv 42" Vent (Standard Deck
51	532069180	Nut Lock #10-24 Unc			- Order Nose Roller and Gauge
52	532139888	Bolt Shoulder 5/16-18 Unc Blkz			Wheel components separately Key
53	532131845	Arm Asm Pad Brake			Nos. 90-95 and 111-121)
54	532133943	Washer Hardened	--	532130794	Mandrel Assembly (Includes Key
55	532155046	Arm Idler 42"mower LT/YT			Numbers 8-10, 12-15, 31 and 33)
56	532165723	Spacer Retainer Mower			

NOTE: All component dimensions given in U.S. inches
1 inch = 25.4 mm

REPAIR PARTS

TRACTOR - MODEL NO. LT15 (J8F1542F), PRODUCT NO. 954 13 00-36

MOWER LIFT

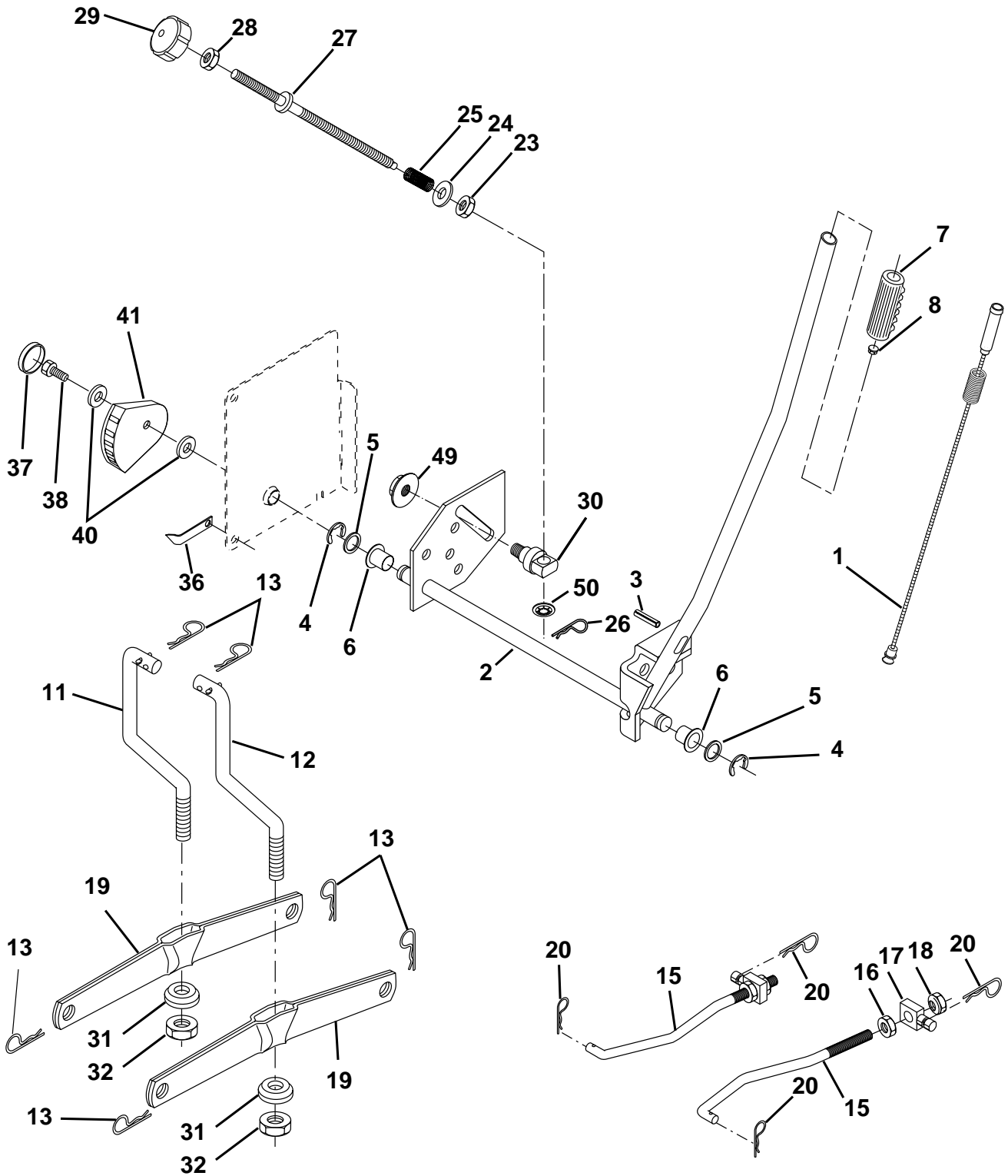

REPAIR PARTS

TRACTOR - MODEL NO. LT15 (J8F1542F), PRODUCT NO. 954 13 00-36

MOWER LIFT

KEY NO.	PART NO.	DESCRIPTION
1	532159460	Wire Asm Inner W/plunger
2	532159471	Shaft Asm Lift RH
3	532105767	Pin Groove 1 500 Zinc
4	812000002	E Ring #5133-62
5	819211621	Washer 21/32 X 1 X 21 Ga
6	532120183	Bearing Nylon Blk 629 Id
7	532125631	Grip Handle Flute Blk.
8	532122365	Button Plunger
11	532139865	Link Lift LH Fixed Length
12	532139866	Link Lift RH Fixed Length
13	532124670	Retainer Spring
15	532173288	Link Front
16	873350800	Nut Jam Hex 1/2-13 Unc
17	532130171	Trunnion Blk Zinc
18	873800800	Nut Lock w/wsh 1/2-13 Unc
19	532139868	Arm Suspension Rear
20	532163552	Retainer Spring
23	532110807	Nut Special
24	819131016	Washer 13/32 X 5/8 X 16 Ga
25	532124874	Spring 2-1/8"
26	532169484	Retainer Clip
27	532126971	Rod Adj Lift Zinc 7.49 Wrk Lg
28	873350600	Nut Hex Jam 3/8-16 Unc
29	532138057	Knob Inf 3/8-16 Unc Blk W/sym
30	532150233	Trunnion Dp Stop Dbl Thds PLT
31	532140302	Bearing Pvt Lift Spherical
32	873540600	Nut Crownlock 3/8-24
36	532155097	Pointer Pnt Height ind .505
37	532123935	Plug Hole Blk 1.485/1.515 Dia.
38	817060516	Screw 5/16-18 x 1
40	819112410	Washer 11/32 x 1-1/2 10 Ga.
41	532155098	Scale Ind. Height Blk.
49	532145212	Nut Hex Flange Lock
50	532110452	Nut Push Phos & Oil

NOTE: All component dimensions given in U.S. inches
1 inch = 25.4 mm

TRACTOR - MODEL NO. LT15 (J8F1542F), PRODUCT NO. 954 13 00-36 SCHEMATIC

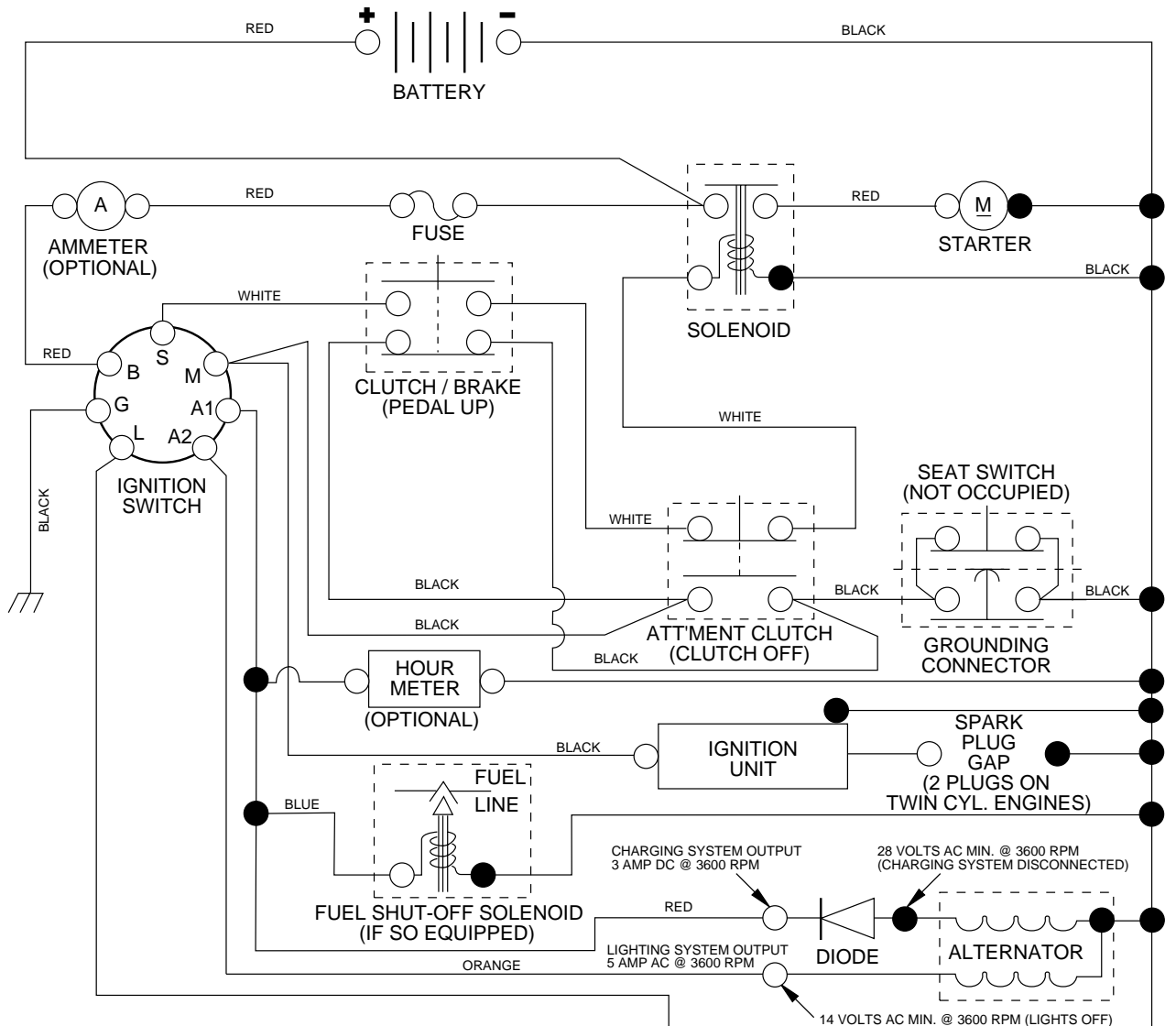

NOTE
YOUR TRACTOR IS EQUIPPED WITH A SPECIAL ALTERNATOR SYSTEM. THE LIGHTS ARE NOT CONNECTED TO THE BATTERY, BUT HAVE THEIR OWN ELECTRICAL SOURCE. BECAUSE OF THIS, THE BRIGHTNESS OF THE LIGHTS WILL CHANGE WITH ENGINE SPEED. AT IDLE THE LIGHTS WILL DIM. AS THE ENGINE IS SPEEDED UP, THE LIGHTS WILL BECOME THEIR BRIGHTEST.

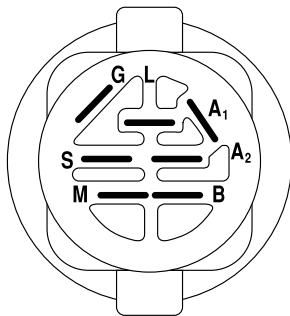

IGNITION SWITCH

POSITION	CIRCUIT	"MAKE"
OFF	M+G+A1	NONE
RUN/LIGHT	B+A1	A2+L
RUN	B+A1	NONE
START	B + S + A1	NONE

WIRING INSULATED CLIPS

NOTE: IF WIRING INSULATED CLIPS WERE REMOVED FOR SERVICING OF UNIT, THEY SHOULD BE REPLACED TO PROPERLY SECURE YOUR WIRING.

NON-REMOVABLE CONNECTIONS

REMOVABLE CONNECTIONS